

Instructions for use
—Type 1 Bonded Fix



Type 1 bonded button-fix

The Button-fix concept is simple: the Fixes are attached to the back of one panel and the mating Buttons are attached to the other. Bring the panels together and slide until the Button-fixes 'click'.

The Type 1 Bonded Fix is moulded in ABS. It is designed for applications where screw-fixing to the panel is not possible and bonding is the preferred option. It can be configured in different ways to best suit your application, either surface-mounted or recessed into the panel, and orientated for vertical or sideways assembly.

Visit the website for more information on the complete Button-fix range, including videos of Button-fix in use. You can also obtain a new copy of these instructions from the website in the event of loss or in the event that Buttonfix modifies the instructions.

Buttonfix Limited retains the right to modify the instructions as it deems appropriate and the consumer is responsible for checking the website for the latest information.

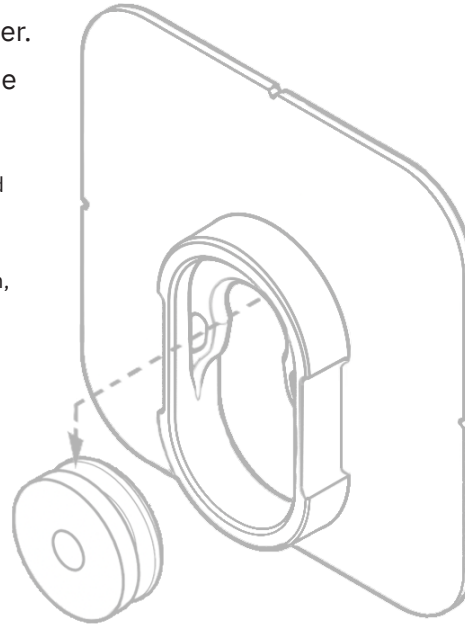

Warnings

—Button-fix is intended for furniture construction and interior fittings and is not intended, nor should it be used, for any other purpose.

—**WARNING:** Serious damage to property and severe bodily injury can result from (1) improper use, application or installation of the Button-fix or (2) use as part of improperly designed or constructed assemblies or materials.

—**WARNING:** Use of adhesives other than the self-adhesive Fix-pads, 2-part structural acrylic adhesive, or solvent weld for bonding to acrylic, may not be effective for proper bonding of the Fix. Buttonfix disclaims any and all liability for use of adhesives other than the Fix-pads.

—Always follow the adhesive manufacturer's recommendations on substrate suitability, preparation and loadings, and perform your own tests as necessary.

—**CAUTION:** Please remember that many factors can affect the use and performance of the Fix-pads in a particular application. The materials to be bonded to the product, the conditions in which the product is used, and the time and environmental conditions in which the product is expected to perform are among the many factors that can affect the use and performance of the Fix-pads, some of which are uniquely within the consumer's knowledge and control. It is essential that the consumer evaluates the Fix-pad to determine whether it is fit for a particular purpose and suitable for the consumer's methods of application.

—When using the self-adhesive Fix-pads, we strongly advise that the Fixes are used in the rebated configuration. If Fix-pads are used in the surface-mounted configuration, the loading should be limited to a maximum of 4.4lbs per Fix.

—Avoid any contact with aggressive solvents and cleaning products.

—It is not possible for Buttonfix to warn the consumer about every possible danger related to use of the Button-fix and the consumer must use his or her own good judgment when installing and using the Button-fix.

The button

There are two Buttons to suit different screw types. These are colour-coded lime green for #10 flat head wood screws, or orange for Ø6.2mm Varianta Euro screws (to fit Ø5mm pilot holes).

Check with your panel supplier which screw type is best for your application.

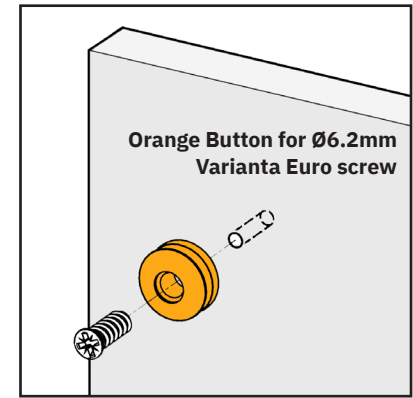
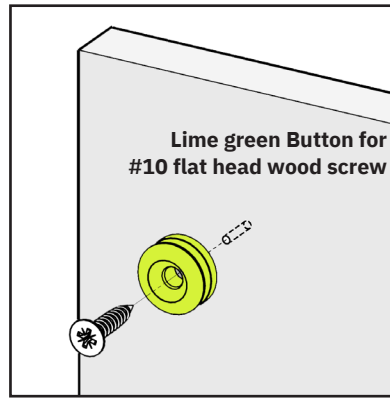

Button marker accessory

The Button marker accessory helps to mark out where to install the Buttons.

Once you have attached the Fix mouldings (see following pages), snap a marker into each one. Then position the second panel and press firmly. The markers will leave indents in the panel surface, which can be used as guides for drilling pilot holes for the Buttons.

Remove the markers, which can be re-used to mark out the next panel.

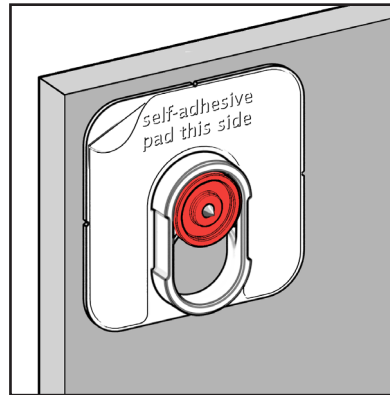

Surface-mounted fix

For applications where it is not possible to machine the panel material, the Fix can be surface-mounted. This creates an 0.32" gap between the panel and the mounting surface.

Care must be taken to ensure the Fixes are correctly bonded to the panel.

It is imperative that all the Fixes on a panel are aligned with each other. Use a square to check alignment.

Vertical arrangement

The Fix may be bonded to the removable panel in a vertical orientation, as shown in the left hand diagram.

In this configuration, the panels engage vertically and 0.6" clearance is required above the removable panel.

Note: the Fix should be inverted if it is bonded to the mounting surface.

Sideways arrangement

The Fix may be bonded to either the removable panel or the mounting surface in a sideways orientation, as shown in the right hand diagram.

In this configuration, the panels engage horizontally and 0.6" clearance is required to the side of the removable panel.

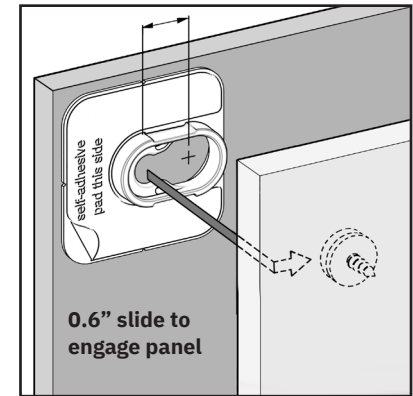
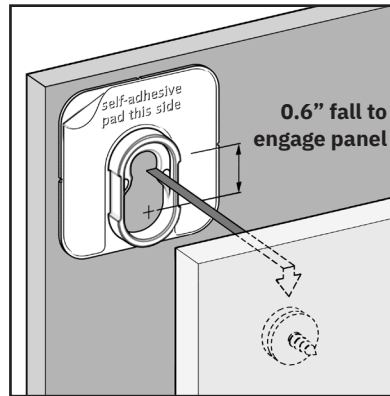
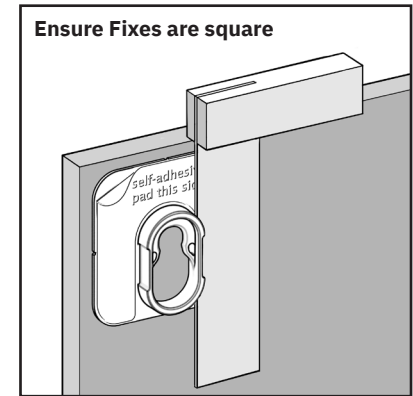
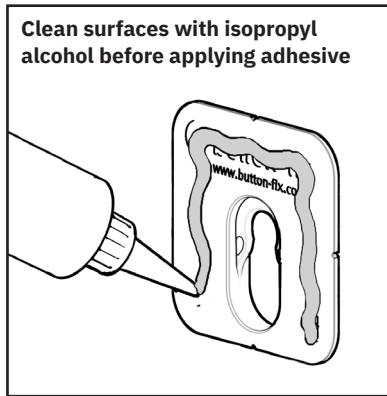

Important: read the notes on page 7 regarding suitable adhesives and surface preparation.

Recessed fix

For applications where it is possible to machine a 0.28" deep recess in the panel, a stronger panel support can be achieved as the rebate supports the Fix in shear. The recess also helps to align the Fix while bonding.

Recessing the Fix creates a nominal 0.08" gap between the two panels

Vertical arrangement

The Fix may be bonded to the removable panel in a vertical orientation, as shown in the left hand diagram.

In this configuration, the panels engage vertically and 0.6" clearance is required above the removable panel.

Note: the Fix should be inverted if it is bonded to the mounting surface.

Sideways arrangement

The Fix may be bonded to either the removable panel or the mounting surface in a sideways orientation, as shown in the right hand diagram.

In this configuration, the panels engage horizontally and 0.6" clearance is required to the side of the removable panel.

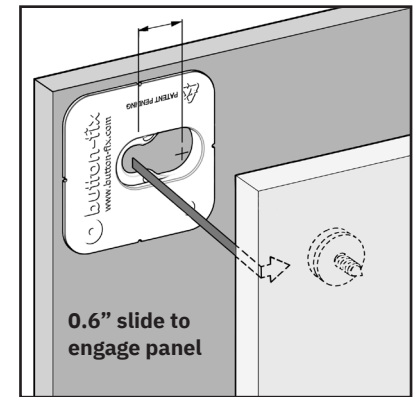
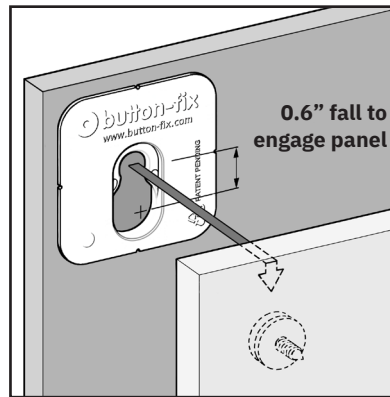
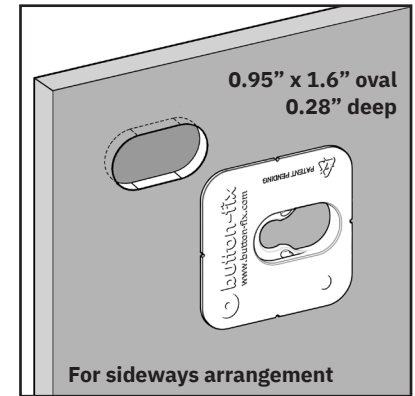
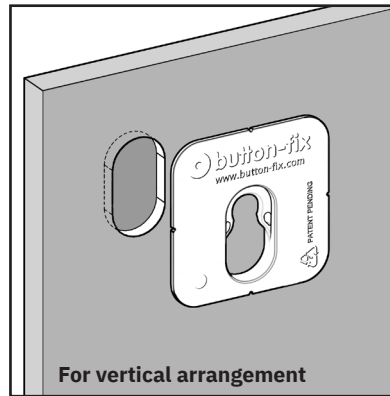

Important: read the notes on page 7 regarding suitable adhesives and surface preparation.

Suitable adhesives

The Fix is manufactured in ABS plastic. There are many structural adhesives suitable for bonding it to a wide range of panel materials, e.g. a 2-part structural acrylic adhesive, a matched adhesive for solid surface (Corian®, Hanex®, etc.) or solvent weld for bonding to acrylic.

Always follow the adhesive manufacturer's recommendations on substrate suitability, preparation and loadings.

Self-adhesive fix-pads

The Fix may also be bonded using self-adhesive Fix-pads (ordered separately).

We strongly advise that the self-adhesive Fix-pads are used in the recessed configuration, shown on the previous page, to avoid possible creep under loading.

If Fix-pads are used in the surface-mounted configuration, the loading should be limited to a maximum of 4.4lbs per Fix.

For best results when using Fix-pads, the surface of the Fix should be abraded using emery paper (180 grit) and both surfaces must be cleaned with isopropyl alcohol.

We highly recommend that the assembled Fixes be clamped to ensure good contact, and should not be fully loaded for at least 24 hours. At room temperature approximately 50% of ultimate bond strength will be achieved after 20 minutes, 90% after 24 hours and 100% after 72 hours.

Abrade surface with emery cloth and clean with isopropyl alcohol

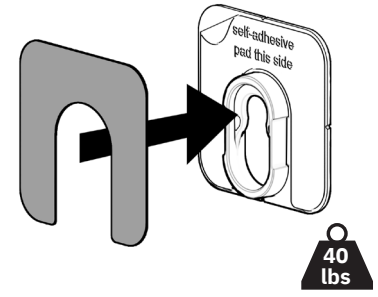

Abrade surface with emery cloth and clean with isopropyl alcohol

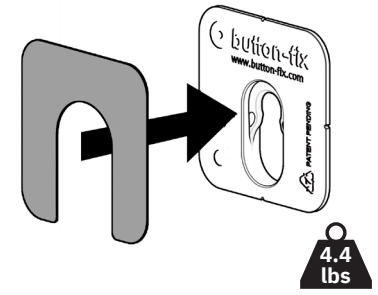

A useful tip

When several Button-fixes are used on a panel, or if you require the panel to be easily removable, first try spraying the fixes with a PTFE or Silicone based lubricant spray.

The strength of the click-fit can be further reduced by adapting some (but not all) the Fix mouldings by snapping off the ears with needle-nosed pliers, as shown in the diagram on the right.

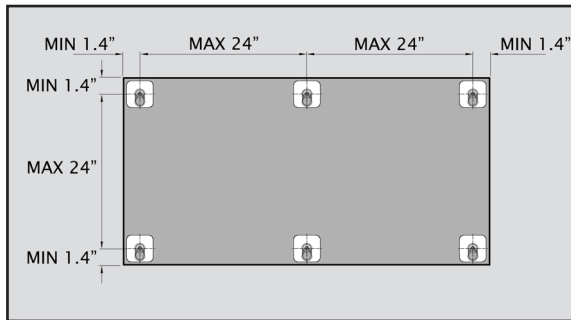
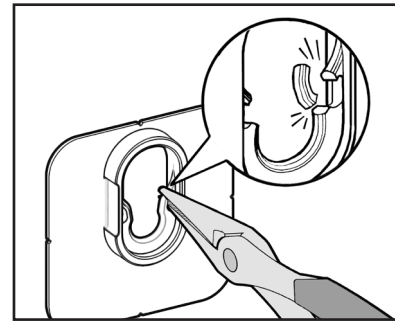

Suggested layout

As an approximate guide, we suggest that Button-fix centres are no greater than 24" apart and no closer than 1.4" to the edge of the panel.

Always remember to allow at least 0.6" clearance for the removable panel to disengage.

Router jig accessory

A router jig can be ordered separately for accurately machining the recesses for the Fixes, described on the previous page.

The jig is designed for use with a metric 12mm cutter and 16mm guide bush. Read the separate instructions supplied with the accessory before use.

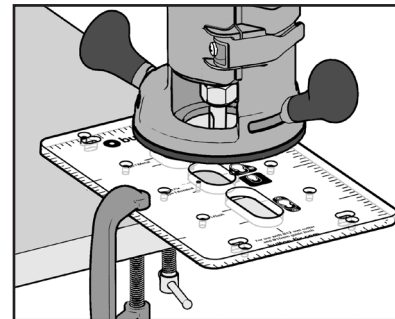

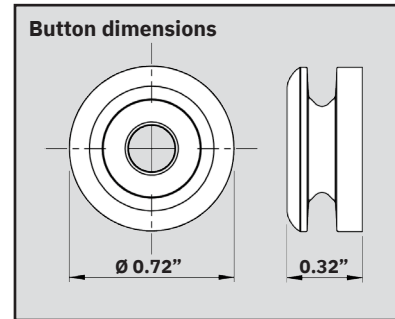
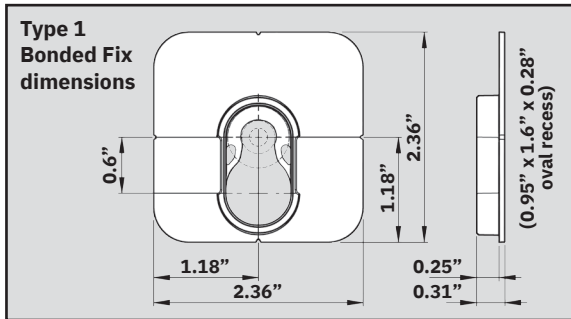

Manufactured in the UK

**Buttonfix Limited
Unit A, 1 Britton Street
London, EC1M 5NW**

T: +44 (0)20 8150 7190

E: info@button-fix.com



button-fix.com